



# LED Pixel Track Pro

ORDERCODE 42205



**SHOWELECTRONICS FOR PROFESSIONALS**

## **Congratulations!**

You have bought a great, innovative product from Showtec.

The Showtec LED Pixel Track Pro brings excitement to any venue. Whether you want simple plug-&-play action or a sophisticated DMX show, this product provides the effect you need.

You can rely on Showtec, for more excellent lighting products.

We design and manufacture professional light equipment for the entertainment industry.

New products are being launched regularly. We work hard to keep you, our customer, satisfied.

For more information: [iwant@showtec.info](mailto:iwant@showtec.info)

You can get some of the best quality, best priced products on the market from Showtec.

So next time, turn to Showtec for more great lighting equipment.

Always get the best -- with Showtec !

Thank you!



<b>Warning</b> .....	2
Safety-instructions.....	2
Operating Determinations.....	3
Rigging.....	3
<b>Description</b> .....	4
Features.....	4
Overview.....	4
Backside.....	4
<b>Installation</b> .....	5
<b>Set Up and Operation</b> .....	6
Panel Functions.....	6
Manual Operation.....	7
Stand-Alone Mode.....	7
Master / Slave Mode.....	7
DMX Operation.....	8
EXAMPLES.....	11
- DMX Channels (MODE 4).....	11
- DMX Channels (MODE 7).....	11
<b>Maintenance</b> .....	12
Changing the Fuse.....	12
<b>Troubleshooting</b> .....	12
<b>Product Specifications</b> .....	13

# WARNING



**FOR YOUR OWN SAFETY, PLEASE READ THIS USER MANUAL CAREFULLY  
BEFORE YOUR INITIAL START-UP!**

## SAFETY INSTRUCTIONS

Every person involved with the installation, operation and maintenance of this device has to:

- be qualified
- follow the instructions of this manual



Before your initial start-up, please make sure that there is no damage caused by transportation. Should there be any, consult your dealer and do not use the device.

To maintain perfect condition and to ensure a safe operation, it is absolutely necessary for the user to follow the safety instructions and warning notes written in this manual.

Please consider that damages caused by manual modifications to the device are not subject to warranty.

This device contains no user-serviceable parts. Refer servicing to qualified technicians only.

### **IMPORTANT:**

*The manufacturer will not accept liability for any resulting damages caused by the non-observance of this manual or any unauthorized modification to the device.*

- Never let the power-cord come into contact with other cables! Handle the power-cord and all connections with the mains with particular caution!
- Never remove warning or informative labels from the unit.
- Never leave any cables lying around.
- Never cover the air vents, otherwise the device will get too hot.
- Do not insert objects into air vents.
- Do not open the device and do not modify the device.
- Do not connect this device to a dimmerpack.
- Do not shake the device. Avoid brute force when installing or operating the device.
- Do not switch the device on and off in short intervals, as this would reduce the system's life.
- Only use device indoors, avoid contact with water or other liquids.
- Only operate the device after having familiarized with its functions.
- Avoid flames and do not put close to flammable liquids or gases.
- Always allow free air space of at least 50 cm around the unit for ventilation.
- Always disconnect power from the mains, when device is not used or before cleaning! Only handle the power-cord by the plug. Never pull out the plug by tugging the power-cord.
- Make sure that the device is not exposed to extreme heat, moisture or dust.
- Make sure that the available voltage is not higher than stated on the rear panel.
- Make sure that the power-cord is never crimped or damaged. Check the device and the power-cord from time to time.
- If device is dropped or struck, disconnect mains power supply immediately. Have a qualified engineer inspect for safety before operating.

- If the device has been exposed to drastic temperature fluctuation (e.g. after transportation), do not switch it on immediately. The arising condensation water might damage your device. Leave the device switched off until it has reached room temperature.
- If your Showtec device fails to work properly, discontinue use immediately. Pack the unit securely (preferably in the original packing material), and return it to your Showtec dealer for service.
- For adult use only. The device must be installed out of the reach of children. Never leave the unit running unattended.
- For replacement use fuses of same type and rating only.
- Repairs, servicing and electric connection must be carried out by a qualified technician.
- WARRANTY: Till one year after date of purchase.

## OPERATING DETERMINATIONS

If this device is operated in any other way, than the one described in this manual, the product may suffer damages and the warranty becomes void.

Any other operation may lead to dangers like short-circuit, burns, electric shock, lamp explosion, crash etc.

You endanger your own safety and the safety of others!

### Rigging

*Please follow the European and national guidelines concerning rigging, trussing and all other safety issues.*

*Do not attempt the installation yourself !*

*Always let the installation be carried out by an authorized dealer !*

### Procedure:

- If the LED Pixel Track Pro is lowered from the ceiling or high joists, professional trussing systems have to be used.
- Use a clamp to mount the LED Pixel Track Pro, with the mounting-bracket, to the trussing system.
- The LED Pixel Track Pro must never be fixed swinging freely in the room.
- The installation must always be secured with a safety attachment, e.g. an appropriate safety net or safety-cable.
- When rigging, derigging or servicing the LED Pixel Track Pro, always make sure, that the area below the installation place is blocked and staying in the area is forbidden.

The LED Pixel Track Pro can be placed on a flat stage floor or mounted to any kind of truss by a clamp.

*Improper installation can cause serious damage to people and property !*

# Description of the device

## Features

The LED Pixel Track Pro is a LED system from Showtec.

- 840 high brightness LEDs
- 15° beam angle
- Digital display
- 3 and 5 PIN DMX input + output connector
- Neutrik input and output power connector
- Power consumption: 70W (full output)
- Flash rate: 20HZ
- Manual color adjustment
- Master/Slave mode
- Sound active mode
- 16 preprogrammed chase
- DMX controlled
- Selectable 4, 7, 8, 20, 40 and 160 DMX channel operation

NOTE: Knowledge of DMX is required to fully utilize this unit.

## Overview

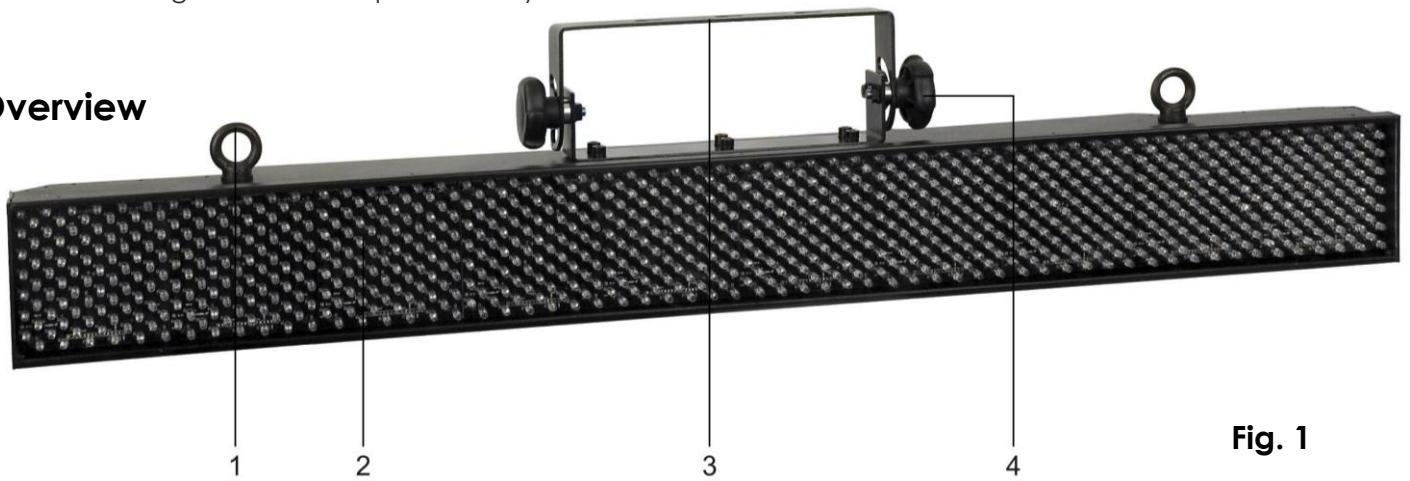

**Fig. 1**

- |   |  |
|---|--|
| <p>1) Safety Eye for Truss mounting<br/>2) Total LED Pixel Track Pro 840 LEDs</p> | <p>3) Mountingbracket for Truss mounting<br/>4) Adjustment Screw</p> |
|---|--|

## Backside

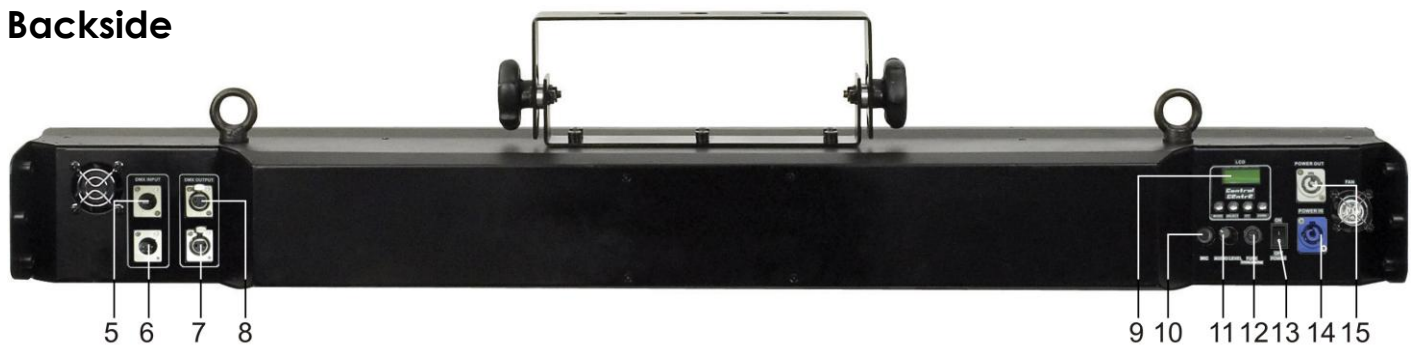

**Fig. 2**

- |  |   |
|--|---|
| <p>5) DMX signal connector (IN) 5-pin<br/>6) DMX signal connector (IN) 3-pin<br/>7) DMX signal connector (OUT) 3-pin<br/>8) DMX signal connector (OUT) 5-pin<br/>9) LCD Display + Menu buttons<br/>10) Mic</p> | <p>11) Audio Level (sensitivity)<br/>12) Fuse T2A<br/>13) On / Off<br/>14) Power OUT<br/>15) Power IN</p> |
|--|---|

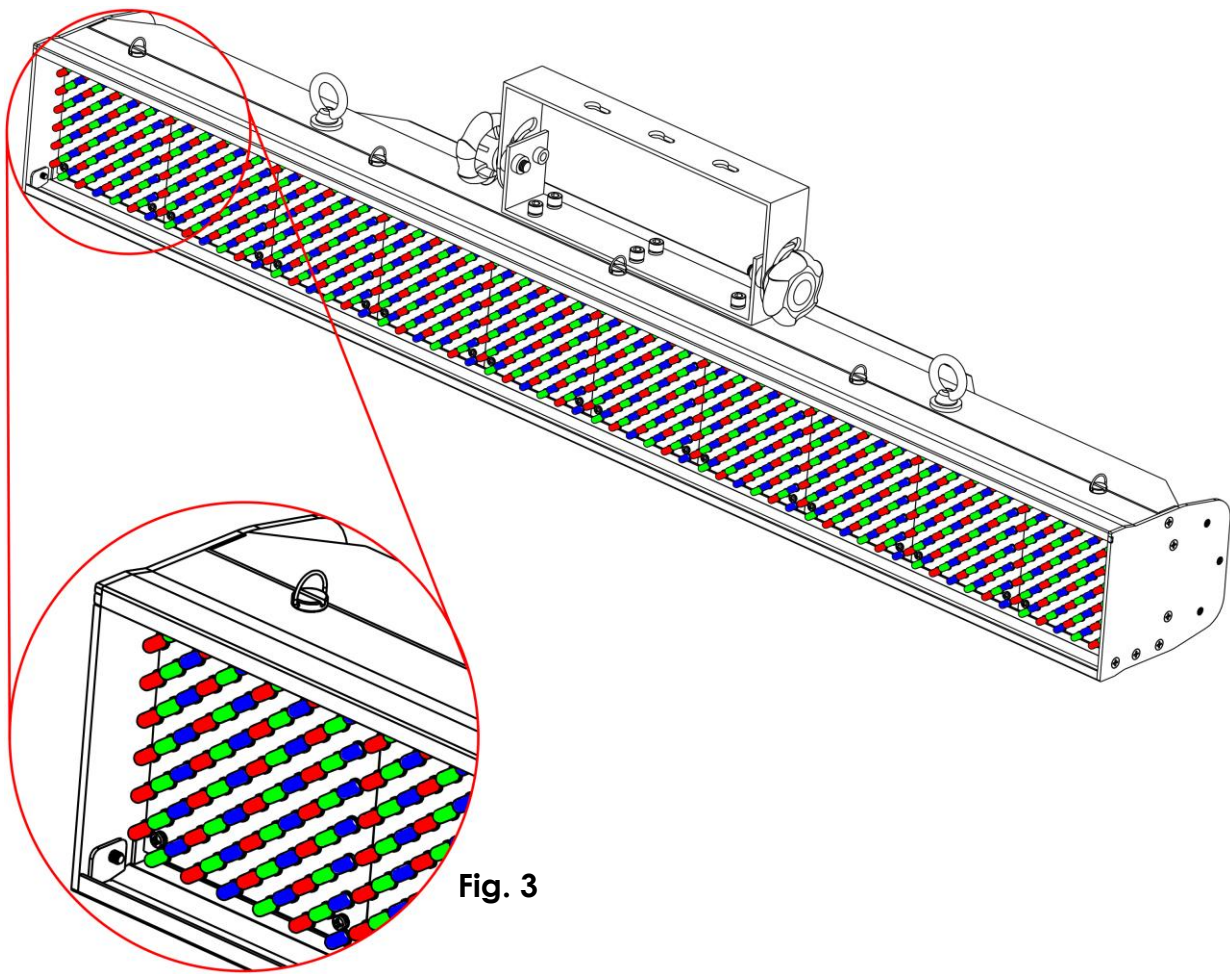

Fig. 3

### Installation

Remove all packing materials from the LED Pixel Track Pro. Check that all foam and plastic padding is removed. Connect all cables.

**Do not supply power before the whole system is set up and connected properly.**

**Always disconnect from electric mains power supply before cleaning or servicing.**

**Damages caused by non-observance are not subject to warranty.**

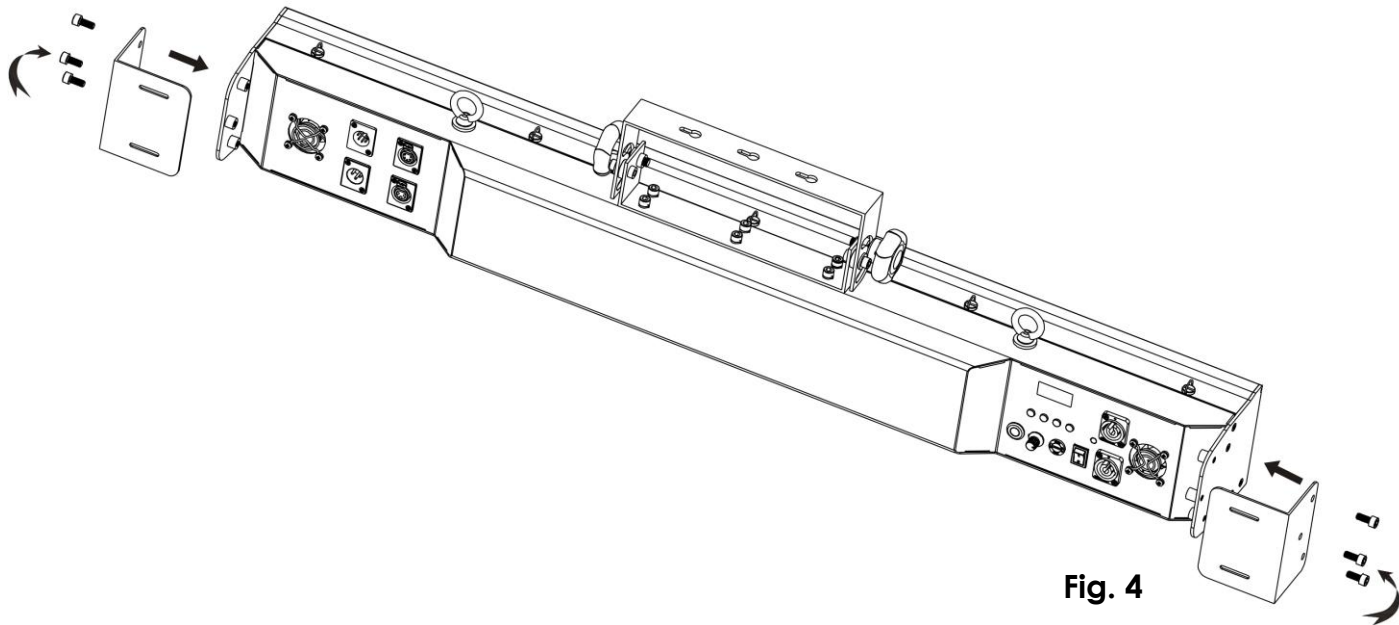

Fig. 4



# Set Up and Operation

Before plugging the unit in, always make sure that the power supply matches the product specification voltage. Do not attempt to operate a 120V specification product on 230V power, or vice versa.

## Panel Functions

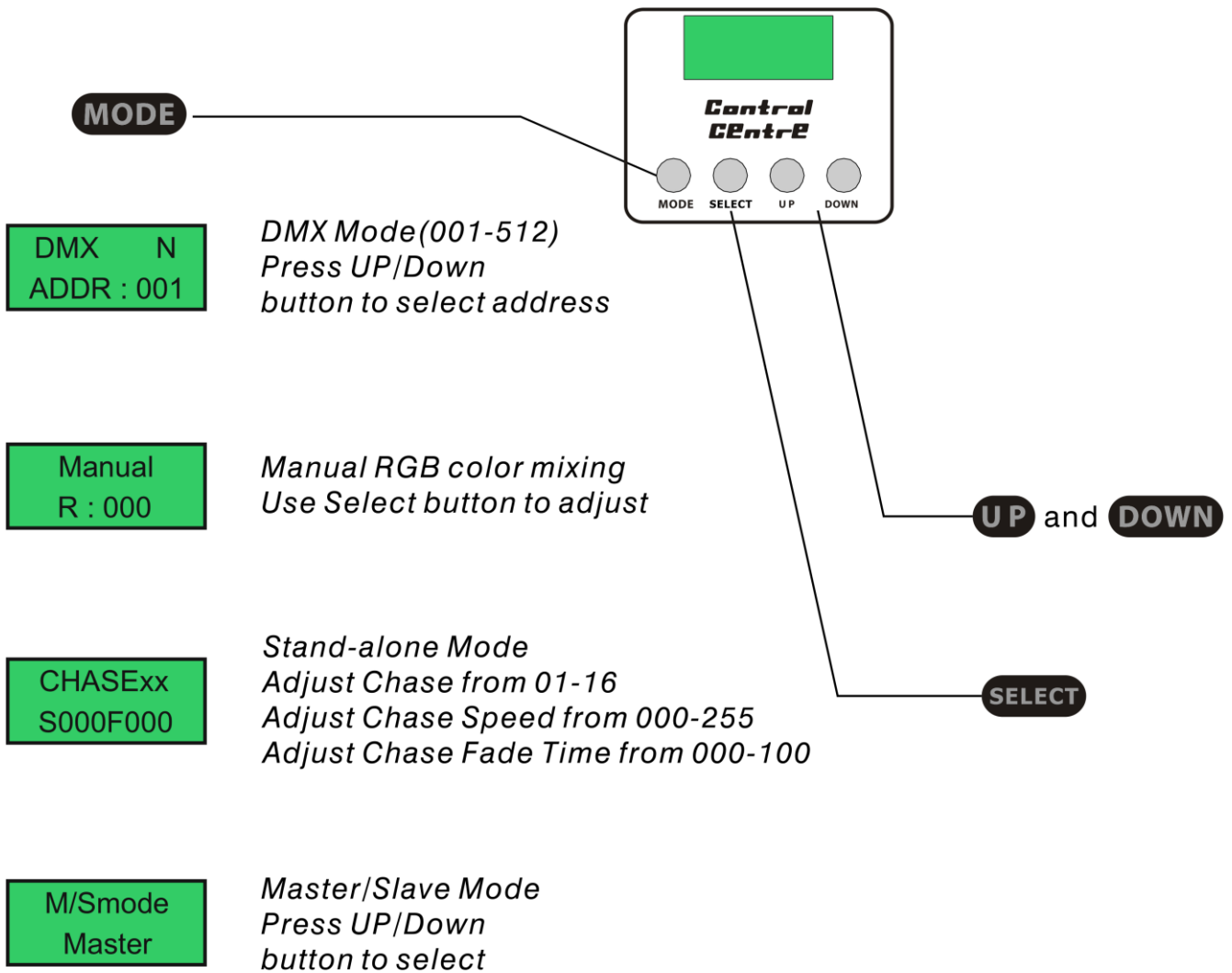
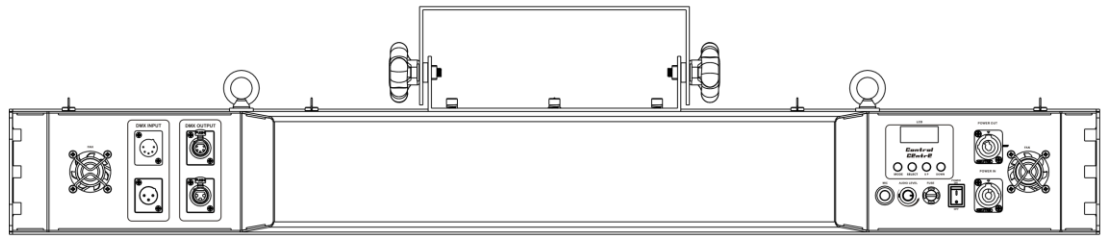

Fig. 5



## Manual Operation

Press the Select button to change between Red, Green or Blue.

Manual  
R : 000

**Red**  
(000-255)

Manual  
G : 000

**Green**  
(000-255)

Manual  
B : 000

**Blue**  
(000-255)

Use the UP/DOWN buttons to change the Color intensity from 0-255.  
You can combine all 3 colors to mix your own desired color.

## Stand-alone Operation

Press the Select button to change Fade, Chase or Speed.  
The underline in the display, shows which setting you can change.

CHASE01  
S000F000

**Fade**  
(000-100)

CHASE01  
S000F000

**Chase**  
(0-16)

CHASE01  
S000F000

**Speed**  
(000-255)

In Chase Mode you can choose: Chase 1-15  
Chase 16 (**sound-controlled**)

Chase 16 is the Sound-controlled mode, you can use the Audio sensitivity control on the back to adjust the audio input level. The display shows.

CHASE16  
Sound

**Note:** in some programs you can not change the fade settings.

## Master / Slave Mode

You can select Master or Slave Mode by using the UP/DOWN buttons.

M/Smode  
Master

M/Smode  
Slave

## DMX Operation

The LED Pixel Track Pro's built-in controller will automatically detect the presence of a DMX signal. When you put the DMX cable in the device, the display will change from N to Y. In order to receive a DMX signal, the built-in controller must be attached to a DMX controller by a 3-pin DMX cable and the DMX controller must be turned on.

DMX N  
ADDR : 001

DMX Y  
ADDR : 001

Select the desired DMX address by pressing the UP/DOWN buttons.

The LED Pixel Track Pro system can operate as a 160-, 40-, 20-, 8-, 7- or 4-channel DMX fixture. Select the desired Mode by pressing the MODE button, you can choose:

DMX Y  
MODE : 160

DMX Y  
MODE : 40

DMX Y  
MODE : 20

DMX Y  
MODE : 8

DMX Y  
MODE : 7

DMX Y  
MODE : 4

**160 Channels**  
**(40 sections)**

**40 Channels**  
**(10 sections)**

**20 Channels**  
**(5 sections)**

**8 Channels**  
**(2 sections)**

**7 Channels**  
**(1 section)**

**4 Channels**  
**(1 section)**

160X	40X	20X	8X	7X	4X
Red	Red	Red	Red	Red	Red
Green	Green	Green	Green	Green	Green
Blue	Blue	Blue	Blue	Blue	Blue
Dimmer	Dimmer	Dimmer	Dimmer	Dimmer	Dimmer
				Chase	
				Speed	
				Fade Time	

Each section or pixel = 7x Red, 7x Green and 7x Blue  
 In the most advanced mode (**MODE 160**) you can control 40 different sections.  
 You can control Red, Green, Blue and Dimmer of each section (4x40).

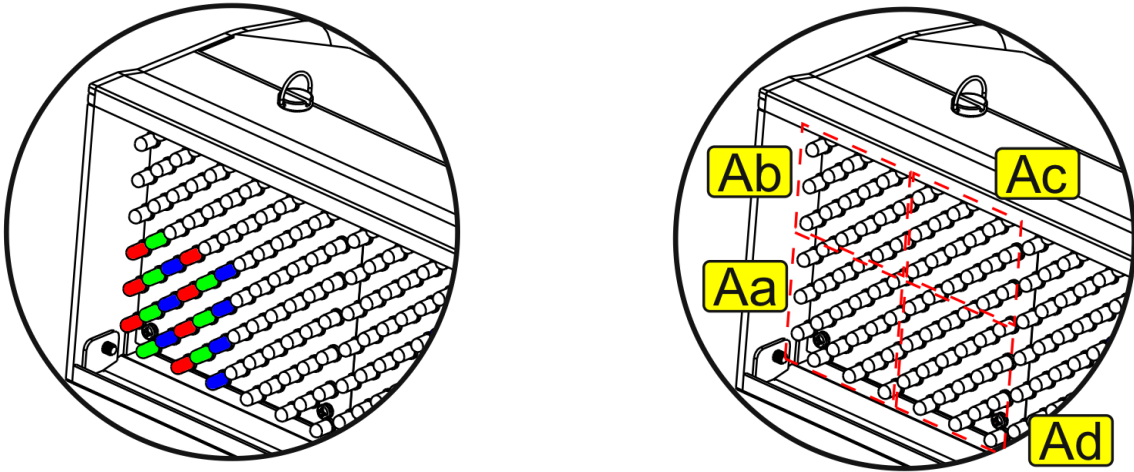

Fig. 6

**1 Section (Pixel):** 7 Red  
 7 Green  
 7 Blue

**4 Sections (Pixels):** Aa  
 Ab  
 Ac  
 Ad

**Main Sections + Sub-sections (Cells)**

A		B		C		D		E		F		G		H		I		J	
b	c	b	c	b	c	b	c	b	c	b	c	b	c	b	c	b	c	b	c
a	d	a	d	a	d	a	d	a	d	a	d	a	d	a	d	a	d	a	d

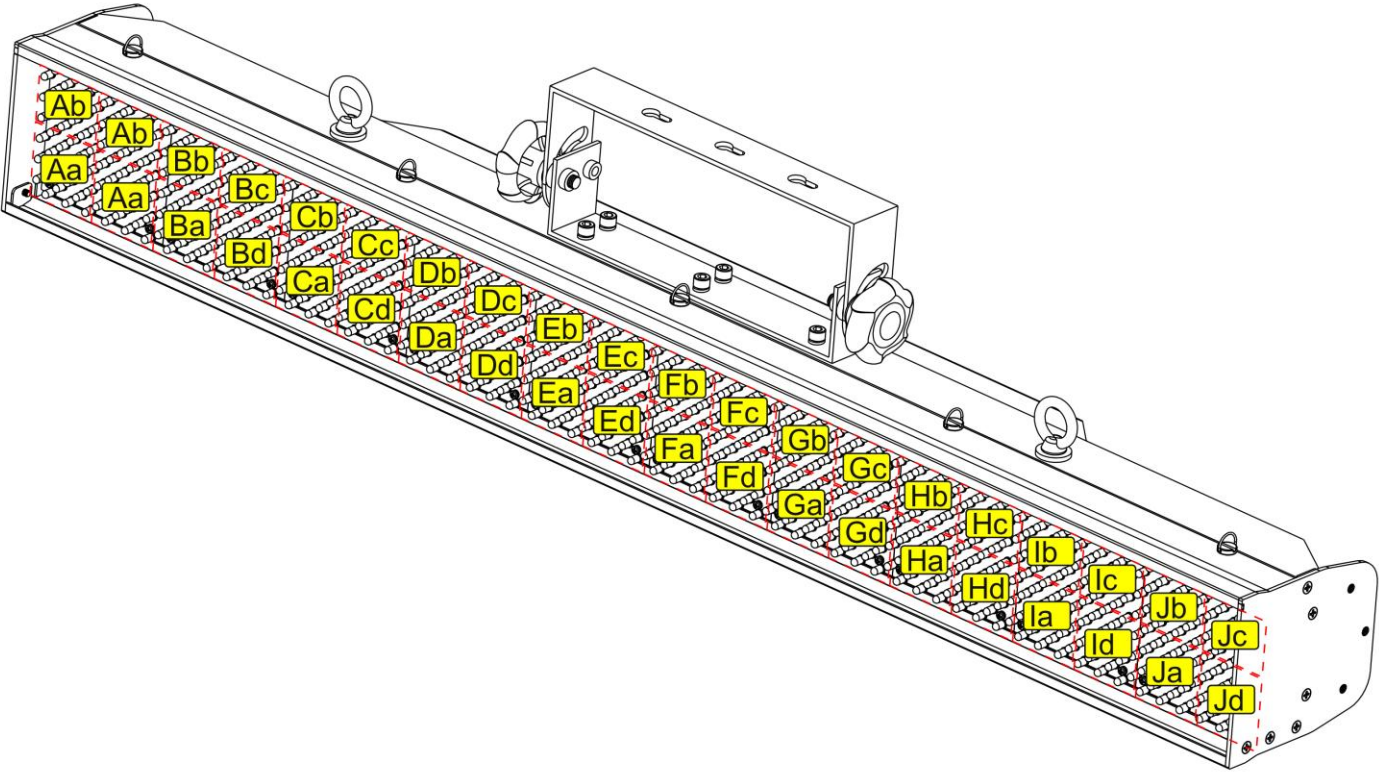

Fig. 7

MODE	160	40	20	8	7	4
R/G/B/Dimmer	R/G/B/Dimmer	R/G/B/Dimmer	R/G/B/Dimmer	R/G/B/Dimmer	R/G/B/Dimmer/ Chase/Speed/Fade	R/G/B/Dimmer
<b>Cells</b>						
Aa	1 2 3 4	1 2 3 4	1 2 3 4	1 2 3 4	1 2 3 4 5 6 7	1 2 3 4
Ab	5 6 7 8	1 2 3 4	1 2 3 4	1 2 3 4	1 2 3 4 5 6 7	1 2 3 4
Ac	9 10 11 12	1 2 3 4	1 2 3 4	1 2 3 4	1 2 3 4 5 6 7	1 2 3 4
Ad	13 14 15 16	1 2 3 4	1 2 3 4	1 2 3 4	1 2 3 4 5 6 7	1 2 3 4
Ba	17 18 19 20	5 6 7 8	1 2 3 4	1 2 3 4	1 2 3 4 5 6 7	1 2 3 4
Bb	21 22 23 24	5 6 7 8	1 2 3 4	1 2 3 4	1 2 3 4 5 6 7	1 2 3 4
Bc	25 26 27 28	5 6 7 8	1 2 3 4	1 2 3 4	1 2 3 4 5 6 7	1 2 3 4
Bd	29 30 31 32	5 6 7 8	1 2 3 4	1 2 3 4	1 2 3 4 5 6 7	1 2 3 4
Ca	33 34 35 36	9 10 11 12	5 6 7 8	1 2 3 4	1 2 3 4 5 6 7	1 2 3 4
Cb	37 38 39 40	9 10 11 12	5 6 7 8	1 2 3 4	1 2 3 4 5 6 7	1 2 3 4
Cc	41 42 43 44	9 10 11 12	5 6 7 8	1 2 3 4	1 2 3 4 5 6 7	1 2 3 4
Cd	45 46 47 48	9 10 11 12	5 6 7 8	1 2 3 4	1 2 3 4 5 6 7	1 2 3 4
Da	49 50 51 52	13 14 15 16	5 6 7 8	1 2 3 4	1 2 3 4 5 6 7	1 2 3 4
Db	53 54 55 56	13 14 15 16	5 6 7 8	1 2 3 4	1 2 3 4 5 6 7	1 2 3 4
Dc	57 58 59 60	13 14 15 16	5 6 7 8	1 2 3 4	1 2 3 4 5 6 7	1 2 3 4
Dc	61 62 63 64	13 14 15 16	5 6 7 8	1 2 3 4	1 2 3 4 5 6 7	1 2 3 4
Ea	65 66 67 68	17 18 19 20	9 10 11 12	1 2 3 4	1 2 3 4 5 6 7	1 2 3 4
Eb	69 70 71 72	17 18 19 20	9 10 11 12	1 2 3 4	1 2 3 4 5 6 7	1 2 3 4
Ec	73 74 75 76	17 18 19 20	9 10 11 12	1 2 3 4	1 2 3 4 5 6 7	1 2 3 4
Ed	77 78 79 80	17 18 19 20	9 10 11 12	1 2 3 4	1 2 3 4 5 6 7	1 2 3 4
Fa	81 82 83 84	21 22 23 24	9 10 11 12	5 6 7 8	1 2 3 4 5 6 7	1 2 3 4
Fb	85 86 87 88	21 22 23 24	9 10 11 12	5 6 7 8	1 2 3 4 5 6 7	1 2 3 4
Fc	89 90 91 92	21 22 23 24	9 10 11 12	5 6 7 8	1 2 3 4 5 6 7	1 2 3 4
Fd	93 94 95 96	21 22 23 24	9 10 11 12	5 6 7 8	1 2 3 4 5 6 7	1 2 3 4
Ga	97 98 99 100	25 26 27 28	13 14 15 16	5 6 7 8	1 2 3 4 5 6 7	1 2 3 4
Gb	101 102 103 104	25 26 27 28	13 14 15 16	5 6 7 8	1 2 3 4 5 6 7	1 2 3 4
Gc	105 106 107 108	25 26 27 28	13 14 15 16	5 6 7 8	1 2 3 4 5 6 7	1 2 3 4
Gd	109 110 111 112	25 26 27 28	13 14 15 16	5 6 7 8	1 2 3 4 5 6 7	1 2 3 4
Ha	113 114 115 116	29 30 31 32	13 14 15 16	5 6 7 8	1 2 3 4 5 6 7	1 2 3 4
Hb	117 118 119 120	29 30 31 32	13 14 15 16	5 6 7 8	1 2 3 4 5 6 7	1 2 3 4
Hc	121 122 123 124	29 30 31 32	13 14 15 16	5 6 7 8	1 2 3 4 5 6 7	1 2 3 4
Hd	125 126 127 128	29 30 31 32	13 14 15 16	5 6 7 8	1 2 3 4 5 6 7	1 2 3 4
Ia	129 130 131 132	33 34 35 36	17 18 19 20	5 6 7 8	1 2 3 4 5 6 7	1 2 3 4
Ib	133 134 135 136	33 34 35 36	17 18 19 20	5 6 7 8	1 2 3 4 5 6 7	1 2 3 4
Ic	137 138 139 140	33 34 35 36	17 18 19 20	5 6 7 8	1 2 3 4 5 6 7	1 2 3 4
Id	141 142 143 144	33 34 35 36	17 18 19 20	5 6 7 8	1 2 3 4 5 6 7	1 2 3 4
Ja	145 146 147 148	37 38 39 40	17 18 19 20	5 6 7 8	1 2 3 4 5 6 7	1 2 3 4
Jb	149 150 151 152	37 38 39 40	17 18 19 20	5 6 7 8	1 2 3 4 5 6 7	1 2 3 4
Jc	153 154 155 156	37 38 39 40	17 18 19 20	5 6 7 8	1 2 3 4 5 6 7	1 2 3 4
Jd	157 158 159 160	37 38 39 40	17 18 19 20	5 6 7 8	1 2 3 4 5 6 7	1 2 3 4

# EXAMPLES

## DMX Channels (MODE 4)

### Channel 1 – Red

0-255	Gradual adjustment Magenta from 0 – 100%
-------	--

### Channel 2 – Green

0-255	Gradual adjustment Magenta from 0 – 100%
-------	--

### Channel 3 – Blue

0-255	Gradual adjustment Magenta from 0 – 100%
-------	--

### Channel 4 – Dimmer / Strobe

0-159	Gradual adjustment dimmer intensity from 0-100%
160-255	Strobe effect from slow to fast

## DMX Channels (MODE 7)

### Channel 1 – Red

0-255	Gradual adjustment Magenta from 0 – 100%
-------	--

### Channel 2 – Green

0-255	Gradual adjustment Magenta from 0 – 100%
-------	--

### Channel 3 – Blue

0-255	Gradual adjustment Magenta from 0 – 100%
-------	--

### Channel 4 – Dimmer / Strobe

0-159	Gradual adjustment dimmer intensity from 0-100%
160-255	Strobe effect from slow to fast

### Channel 5 – Chase / Sound-controlled

0-15	Chase 1
16-31	Chase 2
32-47	Chase 3
48-63	Chase 4
64-79	Chase 5
80-95	Chase 6
96-111	Chase 7
112-127	Chase 8
128-143	Chase 9
144-159	Chase 10
160-175	Chase 11
176-191	Chase 12
192-207	Chase 13
208-223	Chase 14
224-239	Chase 15
240-255	Chase 16 (Sound-controlled)

### Channel 6 – Speed

0-255	Gradual adjustment Speed from 0-100%
-------	--------------------------------------

### Channel 7 – Fade Time

0-255	Gradual adjustment Fade Time from 0-100%
-------	--

## Maintenance

The LED Pixel Track Pro requires almost no maintenance. However, you should keep the unit clean. Disconnect the mains power supply, and then wipe the cover with a damp cloth. Do not immerse in liquid.

Keep connections clean. Disconnect electric power, and then wipe the audio connections with a damp cloth. Make sure connections are thoroughly dry before linking equipment or supplying electric power.

## Replacing a Fuse

Power surges, short-circuit or inappropriate electrical power supply may cause a fuse to burn out. If the fuse burns out, the product will not function whatsoever. If this happens, follow the directions below to do so.

1. Unplug the unit from electric power source.
2. Insert a screwdriver into the slot in the fuse cover. Turn the screwdriver to the left, at the same time gently push a bit (Turn and Push). The fuse will come out. (Fig. 8)
3. Remove the broken fuse. If brown or unclear, it is burned out.
4. Insert the replacement fuse into the holder where the old fuse was. Reinsert the fuse cover. Be sure to use a fuse of the same type and specification. See the product specification label for details.

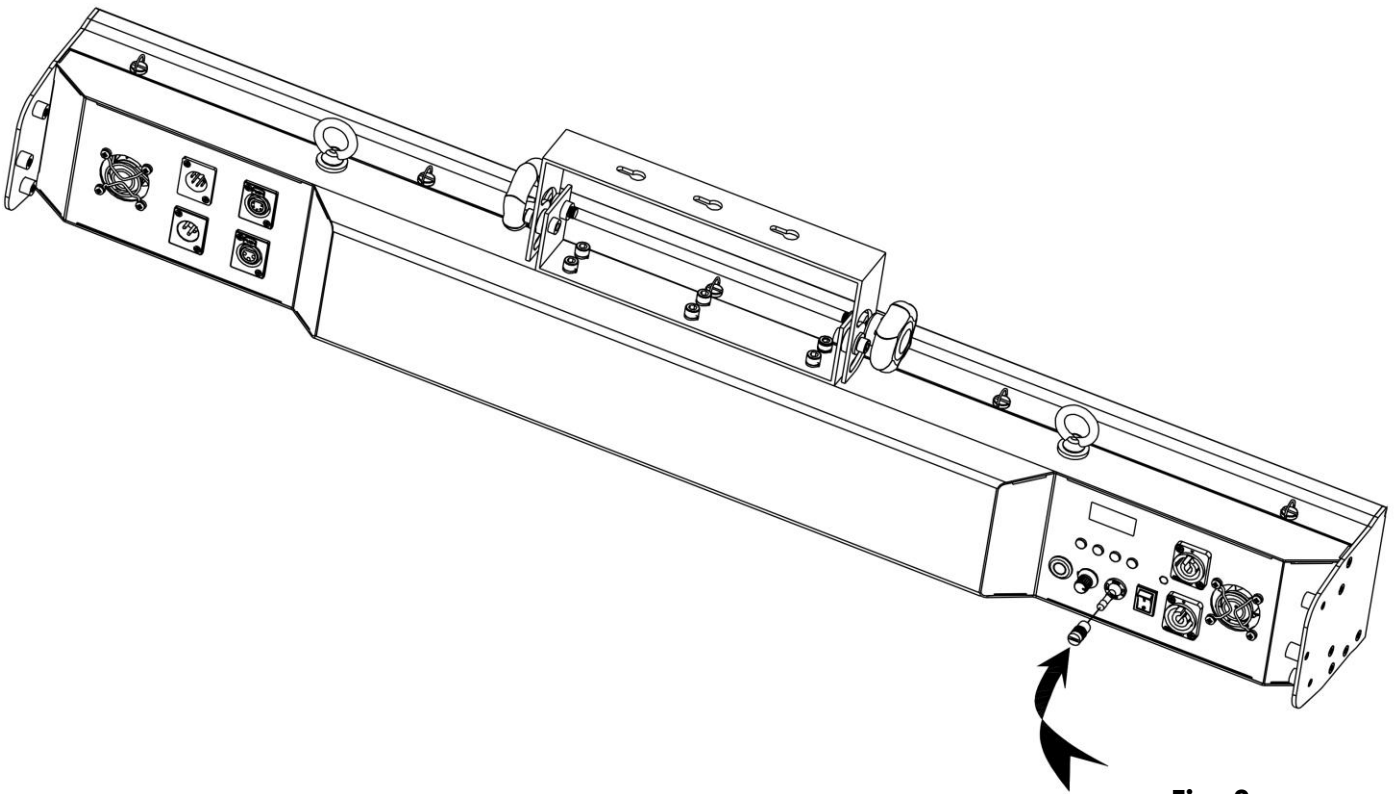

Fig. 8

## Troubleshooting

### Showtec LED Pixel Track Pro

This troubleshooting guide is meant to help solve simple problems.

If a problem occurs, carry out the steps below in sequence until a solution is found. Once the unit operates properly, do not carry out following steps.

1. If the device does not operate properly, unplug the device.
2. Check the fuse, power from the wall, all cables etc.
3. If all of the above appears to be O.K., plug the unit in again.
4. If you are unable to determine the cause of the problem, do not open the LED Pixel Track Pro, as this may damage the unit and the warranty will become void.
5. Return the device to your Showtec dealer.

## Product Specification

Model: Showtec LED Pixel Track Pro  
Voltage : AC 230V-50Hz (CE)  
Power consumption: 70W (full output)  
Fuse: 250V / T2,5A  
Neutrik input and output power connector  
DMX Input : 3+5-pin XLR Male connector  
DMX Output : 3+5-pin XLR Female connector  
Dimensions : 1010 x 175 x 200 mm (LxWxH)  
Weight : 7,14 kg



Selectable 4,7,8,20,40,160 DMX channel operation

### DMX control option

- 4 Channel mode: CH1 Red, CH2 Green, CH3 Blue, Ch4 Dimmer/Strobe
- 7 Channel mode: CH1 Red, CH2 Green, CH3 Blue, Ch4 Dimmer/Strobe, CH5 Preprogrammed chase, CH6 Speed, CH7 Fade
- Control 2 x 5 sections = 8 DMX channels
- Control 5 x 2 sections = 20 DMX channels

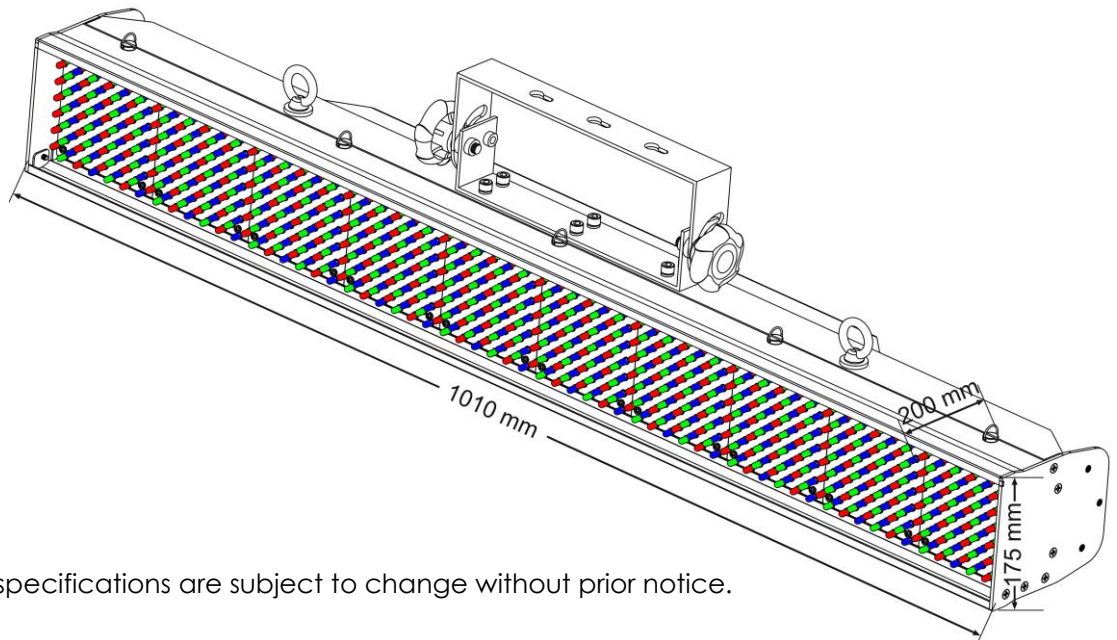

Design and product specifications are subject to change without prior notice.



Website: [www.Showtec.info](http://www.Showtec.info)  
Email: [service@highlite.nl](mailto:service@highlite.nl)





© 2009 Showtec.