

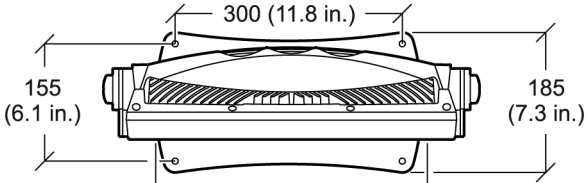

P-5  
P-5 WHITE  
P-5 TUNABLE WHITE

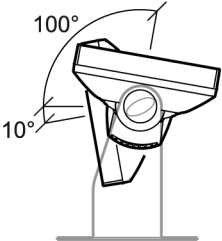

# P-5 Series dimensions

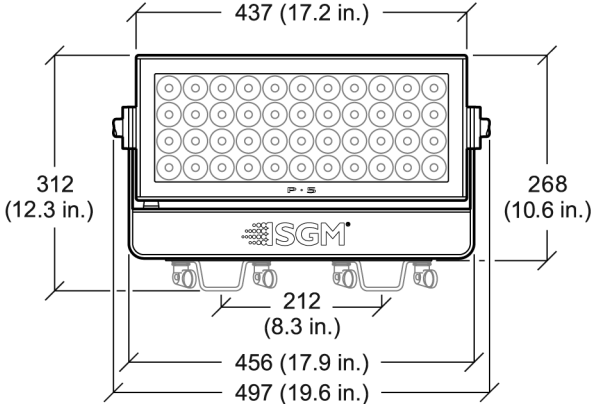
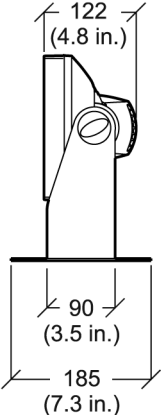

All dimensions in millimeters and inches.  
Drawing not to scale.

# **P-5 WASH LIGHT USER MANUAL REV. 4C**

© 2014 SGM™. Information subject to change without notice. SGM and all affiliated companies disclaim liability for any injury, damage, direct or indirect loss, consequential or economic loss or any other loss occasioned by the use of, inability to use or reliance on the information contained in this manual. The SGM logo, the SGM name and all other trademarks in this document pertaining to services or products by SGM or its affiliates and subsidiaries are trademarks owned or licensed by SGM or its affiliates or subsidiaries.

This edition applies to firmware version 1.35 or later.

**English edition**

# Contents

Safety information.....	6
Overview.....	8
Preparing for installation.....	9
Installing the P-5.....	10
Connecting AC power.....	12
Configuring the device.....	13
Setting a static color manually.....	14
Using stand-alone operation.....	15
Connecting to a DMX control device .....	16
Configuring the device for DMX control .....	17
Device personality settings.....	20

Service.....	22
DMX protocols.....	23
Control menu.....	32
Specifications .....	38

## Safety information



***WARNING!*** Read the safety precautions in this section before installing, powering or operating this product.

**P-5 series luminaires are intended for professional use only. They are not suitable for household use.**

Review the following safety precautions carefully before installing or operating the device.

### *Preventing electric shock*



***DANGER!*** Risk of electric shock. Do not open the device.

- Do not open the device; there are no user-serviceable parts inside.
- Ensure that power is cut off when wiring the device to the AC mains supply.
- Ensure that the device is electrically connected to earth (ground).
- Do not apply power if the device or mains cable is in any way damaged.
- Do not immerse the fixture in water or liquid.



***WARNING! Take measures to prevent burns and fire.***

- Install in a location that prevents accidental contact with the device.
- Install only in a well-ventilated space.
- Install at least 0.3 m (12 in.) away from objects to be illuminated.
- Install only in accordance with applicable building codes.
- Ensure a minimum clearance of 0.1 m (4 in.) around the cooling fans.
- Do not paint, cover, or modify the device, and do not filter or mask the light.
- Keep all flammable materials well away from the device.
- Allow the device to cool for 15 minutes after operation, before touching it.



***WARNING! Take measures to prevent personal injury.***

- Do not look directly at the light source from close range.
- Take precautions to prevent injury due to falls when working at height.
- For permanent installation, ensure that the device is securely fastened to a load-bearing surface with suitable corrosion-resistant hardware.
- For temporary installation with clamps, ensure that the quarter-turn fasteners are turned fully and secure with a suitable safety cable, one that is able to bear 10 times the weight of the device.

## Overview

P-5, P-5 W and P-5 TW luminaires are DMX-controllable, low-profile, IP65-rated, rectangular, LED wash lights. The standard P-5 offers full RGBW color mixing, color temperature control and incorporate 44 10 W LZ4 RGBW Cool White Emitter LED's. The P-5 W (white) is similar, but incorporating white-emitting LEDs. The P-5 TW (tunable white) offers the ability to adjust white color temperature to 2200, 3000, 4000 or 5300 K. The fixtures all provide built-in wireless DMX support, stand-alone programs, dimming, and a lamp life expectancy of 50,000 hours. Three P-5 lens options are available with beam angles of 15°, 21° or 43°.

- A** 44 x 10 W LEDs
- B** Base
- C** Safety wire eyelet
- D** Cooling fans
- E** Tilt lock
- F** DMX in and out
- G** Wireless antenna socket
- H** OLED display
- I** Control panel
- J** Power connection
- K** Tilt lock

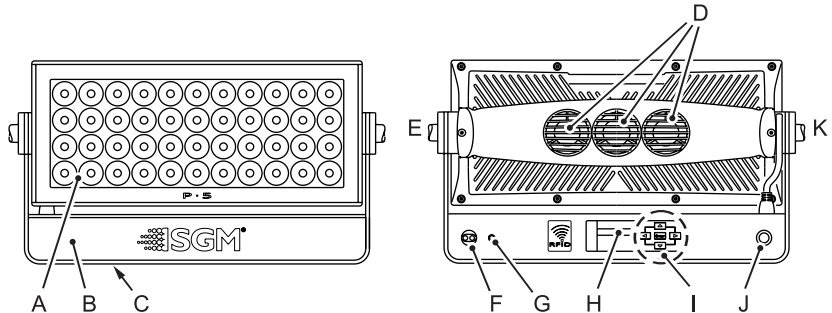



## Preparing for installation

Unpack the device and inspect it to ensure that it has not been damaged in transport.

The P-5 is shipped with two quarter-turn brackets that can be used to mount the device at elevation, and a W-DMX™ G4 wireless antenna.

The fixture has an ingress protection rating of IP65. This means that it is protected from:

- Dust, to the degree that dust cannot enter the device in sufficient quantities as to interfere with its operation.
- Lower pressure jets of water from any direction.

When selecting a location for the device, ensure that it:

- Is situated away from public thoroughfares and protected from contact with people.
- Not immersed in water or exposed to high-pressure water jets.
- Has adequate ventilation.

## Installing the P-5

The P-5 may be installed in any orientation.

For permanent installation on the ground, remove the rubber feet from the floor stand/base. Fasten securely through the resulting holes with four 6 mm (1/4 in.) corrosion-resistant mechanical fasteners suitable for the location.

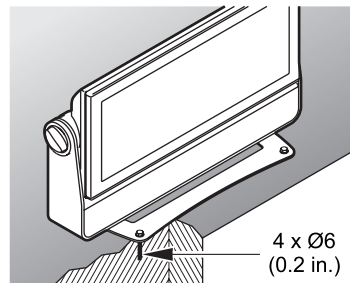
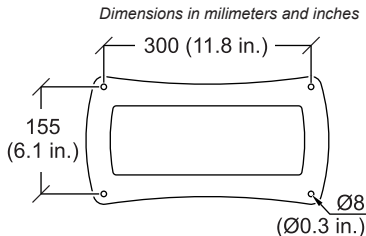

Two quarter-turn brackets are supplied with the device if it is to be flown above the ground. Remove the floor stand/base and rig the P-5 to a support truss or structure using the supplied brackets and suitable clamps.



Fasten a safety cable (not shown) between the support structure and the attachment point on the device. The safety cable must be able to bear at least 10 times the weight of the device.

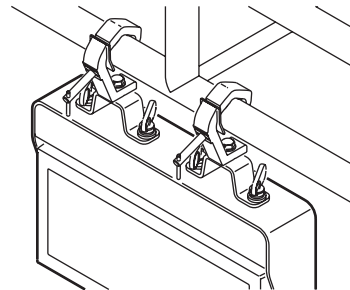



**WARNING!** Always secure an elevated P-5 with a safety cable as backup

The device can be tilted from -10/+100 degrees. To adjust the tilt angle, loosen the two tilt screws, one of each side of the fixture, tilt the device to the angle required and retighten the screws.

If installed horizontally with a downward beam-angle, water can potentially pool in the fan wells. Under normal operation the moisture will evaporate.

***If the device has been operating, always allow it cool for 15 minutes before handling.***

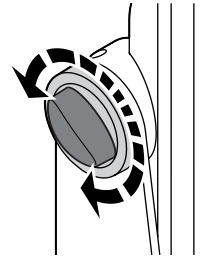

## Connecting AC power





The P-5 can operate on any 208–250 V, 50/60 Hz AC mains power supply. It draws approximately 2 amps at full power.

For permanent installation, have a qualified electrician wire the mains cable directly to a suitable branch circuit. The junction's ingress protection (IP) rating must be suitable for the location.

For temporary installation, the mains cable may be fitted with a grounded connector intended for exterior use.

The power cable color coding is given in the table.

- Connect the black wire to live
- Connect the white wire to neutral
- Connect the green/yellow wire to ground (earth)

<b>Wire</b>	<b>Color</b>	<b>Symbol</b>	<b>Conductor</b>
	Black	<b>L</b>	live
	White	<b>N</b>	neutral
	green/yellow	 or 	ground (earth)

The device must be grounded/earthed and be able to be isolated from AC power. The AC power supply must incorporate a fuse or circuit breaker for fault protection.

After connecting the P-5 to power, run the on-board test, using the “Test→Automated test” menu, to ensure that the device and each LED are functioning correctly. See “Control menu” on page 25.

***Do not open the fixture to replace the supplied power cable, or connect the device to an electrical dimmer system, as this can damage it.***

## Configuring the device

Set up the fixture using the control panel and OLED display at the rear of the fixture.

Navigate the menus and options using the arrow buttons and select items using the Enter button. The options available are listed in “Control menu” on page 32.

After powering the P-5 on, the display shows the currently selected operating mode and other information.

**A** - Operational mode (Quick color, stand-alone or DMX mode)

**B** - DMX address (if DMX mode is active)

**C** - External data indicator (if DMX control is active)

**D** - External data protocol (W-DMX or DMX)

The fixture is set by default to be controlled in DMX mode.

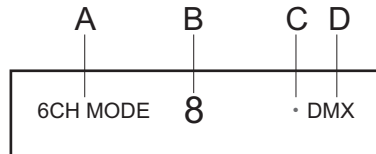
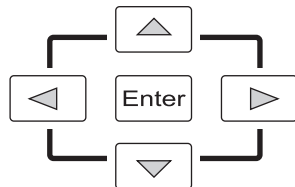

### **Configuring the device using an Android telephone via RFID**

P-5 devices can also be configured wirelessly, via RFID, using the SGM Tool app installed on an Android smart phone that has NFC support (ISO 15693 and ISO 18000-3 mode 1 compatible, operating on 13.56 MHz  $\pm$ 7k Hz carrier frequency).

## Setting a static color manually

The device can be configured to display a predefined and static color (or white, depending on the P-5 model) using the “Manual→Quick color” menus (see “Control menu” on page 32).

Note that whenever the “Manual→Quick color” settings are changed, the fixture will be set by default to automatically start in quick color mode whenever it is powered on. This can be reset using the “Settings→Startup mode→Select startup mode” (see “Control menu” on page 32).

## Using stand-alone operation

Stand-alone operation is where the fixture is not connected to a control device, but is preprogrammed with a series of up to 24 scenes that play continuously in a loop. Up to three stand-alone programs can be defined and run from the menus or one of the programs can be set to run by default whenever the fixture is started.

Each of the three available stand-alone programs contains 24 user-defineable scenes, each scene with its own RGBW (or white) and shutter settings. Each scene has a defineable fade-in time, for the transition from one color (or white) to the next, and a wait (static) time, each of up to 999 minutes and 59 seconds in duration. To program a stand-alone program, use the “Manual→Editor” menus (see “Control menu” on page 32).

Stand-alone mode at fixture startup is enabled using the “Settings→Startup mode→Select startup mode→Standalone” menu. The program to be run is selected using “Settings→Startup mode→Startup program” menu (see “Control menu” on page 32 for a description of the menus). The chosen program will run its length cyclically whenever the fixture is powered on.

A program can be run at any time by selecting it using the “Manual→Run program” menu.

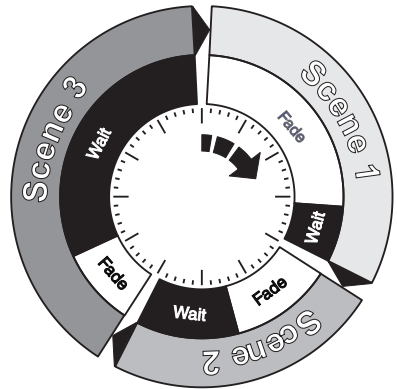

## Connecting to a DMX control device

The device is controllable using a DMX control device and it can be connected using either DMX cable or via the P-5's built-in wireless W-DMX™ G4 receiver system.

If using a cabled DMX system, connect the DMX in cable (with male 5-pin XLR plug) and out cable (with female 5-pin XLR plug) to the DMX data link. Terminate the DMX out cable of the last device in the data link. For outdoor installations, use only IP-rated XLR connectors suitable for outdoor use.

### *Enabling the W-DMX G4 wireless receiver*

The W-DMX™ G4 wireless receiver is disabled by default. Ensure that there is no DMX cable connected to the device. Attach the supplied wireless DMX antenna to the connector on the back of the device.

Use the “Settings→Wireless DMX→Enable” menu to activate wireless DMX and the “Settings→Wireless DMX→Wireless LED Status” to confirm that a data connection has been established. W-DMX™ G4 operates at a frequency of 2.4 GHz, so ensure that the DMX transmitter is configured to operate in this range.

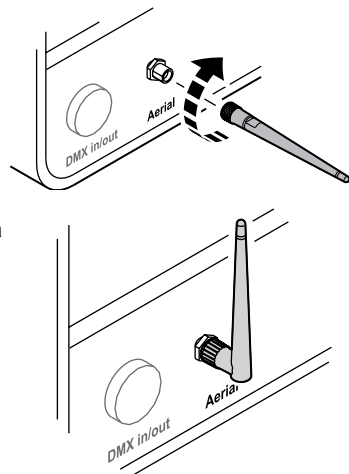



## Configuring the device for DMX control

### ***About DMX***

The P-5 can be controlled using signals sent by a DMX controller on a number of channels (which varies depending on the DMX mode that has been set. The first channel used to receive data from a DMX control device is known as the DMX address. Each P-5 must have a DMX address set. For example, if a P-5 has a DMX address of 10 and it is in 4-channel DMX mode, then it uses channels 10, 11, 12 and 13. The following fixture in the DMX chain could then be set to a DMX address of 14. If two or more DMX devices of the same type have the same DMX address, then they will mimic each other's behavior. Incorrect settings will result in unpredictable responses to the lighting controller.

### ***Setting the DMX address***

The DMX address can be seen at the top of the menu structure. To change the address setting, press the up arrow to increase the address, or the down arrow to decrease the setting. When the desired address is displayed, press Enter to save the setting. For your convenience, the suggested DMX address of the next fixture is displayed to the right. Note that channel spacing is determined by the DMX mode.



See the “DMX protocols” on page 23 for specific DMX control values.

### **Setting the DMX mode**

Using the “DMX mode” menu available from the control panel, specify the DMX mode that provides the device controls that you require:

<b>P-5 DMX modes</b>	<b>Function</b>
3	Individual control of color channels for red, green & blue. White is automatically mixed in.
4	Individual control of color channels for red, green, blue and white (RGBW).
6	RGBW, dimmer, shutter, strobe, pulse & open shutter effects.
8	RGBW with fine control of individual colors.
9	Dimmer and RGBW, with fine control of individual colors.
10	Dimmer and RGBW, with fine control.

<b>P-5 TW DMX modes</b>	<b>Function</b>
2	Dimmer & white temperature control (2200K-5300K).
4	White temperature control - 2200K, 3000K, 4000K and 5300K.
6	Dimmer, white temperature control (2200K, 3000K, 4000K and 5300K), shutter, strobe, pulse & open shutter effects.
8	Fine and coarse control of white temperatures (2200K, 3000K, 4000K and 5300K)

P-5 W DMX modes	Function
1	Dimmer.
2	Dimmer, shutter, strobe, pulse & open shutter effects.
2 (16-bit)	Fine and coarse dimmer.

## Device personality settings

### ***Setting the dimming curve***

The dimming curve is the degree of fineness in control available at low light levels, linear or gamma corrected. Linear control provides uniform adjustment throughout the control action, whereas gamma corrected dimming provides finer control at low light levels, where the eye is more sensitive to change. By default, the P-5 uses gamma corrected dimming. For uniform response, set all devices to the same dimming curve. To set the desired dimming curve, use the “Settings→Dimming curve” menu.

### ***Flipping the OLED display***

If the device is installed hanging upside down, it might be a useful to flip the screen so that it is easy to read. To flip the display, use the “Settings→Flip display” menu, or press the up and down buttons on the control panel at the same time.

### ***Setting the OLED display saver***

By default the OLED display turns off after a short period when the control panel is not in use, but it can be set so that it dims. Pressing any key will always turns on the display or restore it to normal brightness. To enable the display saver, use the “Settings→Display saver” menu.

### ***Setting the fan mode***

For operating environments where low-noise is a requirement or where the fixture will be operating in high temperatures, it is possible to adjust the default fan speed to low or high using the “Settings→Fan mode” menu.

## **Service**

There are no user-serviceable components in the device. Do not open the P-5, as doing so is likely to damage its ingress protection. Consult your SGM dealer if the device operates abnormally, is defective or otherwise in need of service or repair.

### ***Upgrading the firmware***

The firmware installed on the fixture can be identified using the “Info→Firmware version” menu. We recommend that you keep your device's firmware current. Visit <http://www.sgmsupport.com> to obtain the most up-to-date firmware. To perform firmware updates, you need a Windows personal computer and an SGM USB 5-Pin-XLR upload cable (available from your SGM distributor: P/N 40500201).

### ***Cleaning***

To obtain optimal performance, regular cleaning is essential. Cleaning schedules will vary greatly depending on the operating environment, and the installation should therefore be checked at frequent intervals within the first few weeks of operation to see whether cleaning is necessary. This procedure will allow you to assess cleaning requirements in your particular situation. If in doubt, consult your SGM dealer for a suitable maintenance schedule. Clean the P-5 using a soft cloth dampened with a solution of water and a mild detergent. Do not use products that contain solvents, abrasives or caustic agents for cleaning, as they can cause damage to both hardware, cables and connectors.

## DMX protocols

Configuring DMX is described in “Setting the DMX mode” on page 18. This section contains “P-5 DMX protocols” (below), “P-5 W DMX protocols” on page 28, and “P-5 TW DMX protocols” on page 29.

### *P-5 DMX protocols*

<b>P-5 - 3 channel mode - RGB plus auto white</b>			
<b>Channel</b>	<b>Value</b>	<b>Percent</b>	<b>Function</b>
1	0-255	0-100	Red 0-100%
2	0-255	0-100	Green 0-100%
3	0-255	0-100	Blue 0-100%

<b>P-5 - 4 channel mode - RGBW</b>			
<b>Channel</b>	<b>Value</b>	<b>Percent</b>	<b>Function</b>
1	0-255	0-100	Red 0-100%
2	0-255	0-100	Green 0-100%
3	0-255	0-100	Blue 0-100%
4	0-255	0-100	White 0-100%

**P-5 - 6 channel mode - RGBW plus effects**

<b>Channel</b>	<b>Value</b>	<b>Percent</b>	<b>Function</b>
1	0-7	0-2	Shutter Blackout
	8-15	3-6	Shutter Open
	16-151	7-58	Variable Strobe
	152-175	59-68	Pulse Open
	176-199	69-78	Pulse Close
	200-244	79-95	Variable Random Strobe
	245-255	96-100	Shutter Open
2	0-255	0-100	Dimmer 0-100%
3	0-255	0-100	Red 0-100%
4	0-255	0-100	Green 0-100%
5	0-255	0-100	Blue 0-100%
6	0-255	0-100	White 0-100%



**P-5 - 8 channel mode (16-Bit) - RGBW plus fine**

<b>Channel</b>	<b>Value</b>	<b>Percent</b>	<b>Function</b>
1	0-255	0-100	Red 0-100% (MSB)
2	0-255	0-100	Red Fine (LSB)
3	0-255	0-100	Green 0-100% (MSB)
4	0-255	0-100	Green Fine (LSB)
5	0-255	0-100	Blue 0-100% (MSB)
6	0-255	0-100	Blue Fine (LSB)
7	0-255	0-100	White 0-100% (MSB)
8	0-255	0-100	White Fine (LSB)

**P-5 - 9 channel mode (16-Bit) - Dimmer & RGBW plus fine**

<b>Channel</b>	<b>Value</b>	<b>Percent</b>	<b>Function</b>
1	0-255	0-100	Dimmer 0-100%
2	0-255	0-100	Red 0-100% (MSB)
3	0-255	0-100	Red Fine (LSB)
4	0-255	0-100	Green 0-100% (MSB)
5	0-255	0-100	Green Fine (LSB)
6	0-255	0-100	Blue 0-100% (MSB)
7	0-255	0-100	Blue Fine (LSB)
8	0-255	0-100	White 0-100% (MSB)
9	0-255	0-100	White Fine (LSB)

**P-5 - 10 channel mode (16-Bit) - RGBW plus fine**

<b>Channel</b>	<b>Value</b>	<b>Percent</b>	<b>Function</b>
1	0-255	0-100	Dimmer 0-100% (MSB)
2	0-255	0-100	Dimmer Fine (LSB)
3	0-255	0-100	Red 0-100% (MSB)
4	0-255	0-100	Red Fine (LSB)
5	0-255	0-100	Green 0-100% (MSB)
6	0-255	0-100	Green Fine (LSB)
7	0-255	0-100	Blue 0-100% (MSB)
8	0-255	0-100	Blue Fine (LSB)
9	0-255	0-100	White 0-100% (MSB)
10	0-255	0-100	White Fine (LSB)

### *P-5 W DMX protocols*

<b>P-5W - 1 channel mode - Dimmer</b>			
<b>Channel</b>	<b>Value</b>	<b>Percent</b>	<b>Function</b>
1	0-255	0-100	Dimmer 0-100%

<b>P-5W - 2 channel mode - Strobe &amp; dimmer</b>			
<b>Channel</b>	<b>Value</b>	<b>Percent</b>	<b>Function</b>
1	0-7	0-3	Shutter Blackout
	8-15	4-5	Shutter Open
	16-151	6-59	Variable Strobe
	152-175	60-69	Variable Pulse Open
	176-199	70-78	Variable Pulse Close
	200-244	79-96	Variable Random Strobe
	245-255	97-100	Shutter Open
2	0-255	0-100	Dimmer 0-100%

**P-5W - 2-channel mode (16-bit) - Fine & coarse dimmer**

Channel	Value	Percent	Function
1	0-255	0-100	Dimmer 0-100% (MSB)
2	0-255	0-100	Fine dimmer (LSB)

***P-5 TW DMX protocols*****P-5TW - 2-channel mode - Dimmer/CTC**

Channel	Value	Percent	Function
1	0-255	0-100	Dimmer 0-100%
2	0-255	0-100	CTC 0-100% 2200K-5300K

**P-5TW - 4-channel mode - Tunable white**

Channel	Value	Percent	Function
1	0-255	0-100	White 2200K 0-100%
2	0-255	0-100	White 3000K 0-100%
3	0-255	0-100	White 4000K 0-100%
4	0-255	0-100	White 5300K 0-100%

**P-5TW - 6 channel mode - Strobe, dimmer & tunable white**

Channel	Value	Percent	Function
1	0-7	0-3	Shutter Blackout
	8-15	4-5	Shutter Open
	16-151	6-59	Variable Strobe
	152-175	60-69	Variable Pulse Open
	176-199	70-78	Variable Pulse Close
	200-244	79-96	Variable Random Strobe
	245-255	97-100	Shutter Open

2	0-255	0-100	Dimmer 0-100%
3	0-255	0-100	White 2200K 0-100%
4	0-255	0-100	White 3000K 0-100%
5	0-255	0-100	White 4000K 0-100%
6	0-255	0-100	White 5300K 0-100%

**P-5TW - 8-channel mode - Tunable white, coarse & fine**

Channel	Value	Percent	Function
1	0-255	0-100	White 2200K 0-100%
2	0-255	0-100	White 2200K fine
3	0-255	0-100	White 3000K 0-100%
4	0-255	0-100	White 3000K fine
5	0-255	0-100	White 4000K 0-100%
6	0-255	0-100	White 4000K fine
7	0-255	0-100	White 5300K 0-100%
8	0-255	0-100	White 5000K fine

## Control menu

Level 1	Level 2	Level 3	Function	
DMX Mode	x Channel Mode	-	Selects DMX mode. See “Setting the DMX mode” on page 18 for information about the features of each mode.	
Info	Product type	-	Displays the fixture product type.	
	Firmware Version	-	Displays installed software version number.	
	Serial number	-	Displays the fixture serial number.	
	RDM ID	-	Displays the fixture RDM ID (for use with the SGM Tool app)	
	DMX View	-	Displays received DMX levels.	
	Temperatures	Mainboard		Displays temperature on main circuit board.
		LED Panel		Displays temperature on LED display panel.
	Log	-	Displays recorded operating data and error codes.	
Debug	-	Service use only.		



Level 1	Level 2	Level 3	Function
Settings	Wireless DMX	Log Off	Sends log off command to W-DMX™ system.
		Wireless LED status	Blinking - not connected to data Solid - connected to data
		Enable	Enables wireless DMX operation.
		Disable	Disables wireless DMX operation.
	Startup mode	Select startup mode	Default operating mode when the fixture is powered on: 1. Quick color 2. Stand-alone 3. DMX (factory default)
		Startup program	Stand-alone program 1, 2 or 3. Only used if the startup mode is set to "stand-alone". 1 is the default.
	Dimming Curve	Linear	Provides equal resolution dimming from 0 to 100%.
		Gamma Corrected	Provides high resolution dimming at low levels.
	Flip Display	Disable	Selects normal control panel display.
		Enable	Flips control panel display.

Level 1	Level 2	Level 3	Function
Settings continued...	Display Saver	Screen Dim	Dims the OLED display, when the control panel is not in use
		Screen Off	Turns off OLED display, when the control panel is not in use.
	Fan mode	Standard	Adjust fan speed relative to fixture internal temperature.
		Silent	Low fan speed for quiet operation.
		Max power	High fan speed for maximum cooling effect.
	Minimum values	Min. red (P-5)	Adjust default minimum setting (0-1000).
		Min. green (P-5)	
		Min. blue (P-5)	
		Min. white (P-5)	
		Min. line 1 (P-5W)	
		Min. line 2 (P-5W)	
		Min. line 3 (P-5W)	
		Min. line 4 (P-5W)	
		Min. 2200 K (P-5TW)	
		Min. 3000 K (P-5TW)	
Min. 4000 K (P-5TW)			
Min. 5300 K (P-5TW)			

Level 1	Level 2	Level 3	Function
Settings continued...	Factory default	-	Reset the fixture to factory default settings.
Manual	Quick color	Red (P-5)	Static quick color - red mix (0-255). Sets fixture to quick color startup mode.
		Green (P-5)	Static quick color - green mix (0-255). Sets fixture to quick color startup mode.
		Blue (P-5)	Static quick color - blue mix (0-255). Sets fixture to quick color startup mode.
		White (P-5/P-5W)	Static quick color - white mix (0-255). Sets fixture to quick color startup mode.
		2200 KELVIN (P-5TW)	Static quick color - white temperature 2200 K mix (0-255). Sets fixture to quick color startup mode.
		3000 KELVIN (P-5TW)	Static quick color - white temperature 3000 K mix (0-255). Sets fixture to quick color startup mode.
		4000 KELVIN (P-5TW)	Static quick color - white temperature 4000 K mix (0-255). Sets fixture to quick color startup mode.
		5300 KELVIN (P-5TW)	Static quick color - white temperature 5300 K mix (0-255). Sets fixture to quick color startup mode.

Level 1	Level 2	Level 3	Function	
Manual continued...	Run program	1, 2 or 3	Run one of the three user programs.	
	Stop program	-	Stop running program.	
	Editor	Program		Currently selected program (1, 2 or 3).
		Scene		Currently selected scene (1-24).
		Red (P-5)		Red value in currently selected scene (0-255).
		Green (P-5)		Green value in currently selected scene (0-255).
		Blue (P-5)		Blue value in currently selected scene (0-255).
		White (P-5/P-5W)		White value in currently selected scene (0-255).
		2200 KELVIN (P-5TW)		2200 K white temperature value in currently selected scene (0-255).
		3000 KELVIN (P-5TW)		3000 K white temperature value in currently selected scene (0-255).
		4000 KELVIN (P-5TW)		4000 K white temperature value in currently selected scene (0-255).
		5300 KELVIN (P-5TW)		5300 K white temperature value in currently selected scene (0-255).

Level 1	Level 2	Level 3	Function	
Manual continued...	Editor continued...	Shutter	Shutter setting in currently selected scene (0-255):	
			0-7	Shutter Blackout
			8-15	Shutter Open
			16-151	Variable Strobe
			152-175	Pulse Open
			176-199	Pulse Close
			200-244	Variable Random Strobe
			245-255	Shutter Open
		Fade time min.	Fade-in (transition) time to current scene in minutes (0-999).	
		Fade time sec.	Fade-in (transition) time to current scene in seconds (0-59).	
		Wait time min.	Wait (static) time in current scene in minutes (0-999).	
Wait time sec.	Wait (static) time in current scene in seconds (0-59).			
Test	Off	-	Stops test sequence execution.	
	Automated Test	-	Initiates a self-test sequence.	
	Burn In Test 30 min	-	Service use only.	
	Display test	-	Service use only.	

## Specifications

### PHYSICAL

Length x width x height..... 497 x 185 x 300 mm (19.6 x 7.3 x 11.8 in.)  
Weight ..... 8.9 kg (19.6 lbs.)

### LIGHT SOURCE AND OPTICS

Illumination source.....44 x 10 W power LEDs  
Expected lifetime ..... 50,000 hours  
Luminous flux ..... 25,800 lumens  
Spread angle ..... 15°, 21° or 43° lenses available  
White temperatures (P-5TW)..... 2200 K, 3000 K, 4000 K and 5300 K

### CONSTRUCTION

Housing ..... Aluminium  
Finish ..... Electrostatic powder coating

### INSTALLATION

Orientation ..... Any  
Minimum distance between units ..... Horizontal: 0 mm, Vertical: 40 mm (1.6 in.)

## OPERATING CONDITIONS

Ambient temperature range ( $T_a$ ) .....	-10° to 40° C (14° to 104° F)
Maximum relative humidity .....	98%
IP rating .....	IP 65

## PROGRAMMING AND CONTROL

Control interface .....	USITT DMX 512-A (serial cable) or W-DMX™ G4 (wireless)
DMX channel requirements .....	3 to 10 channels (mode dependent)
Local control .....	5 button panel with OLED graphical display
Software update .....	via Windows PC and SGM USB 5-Pin-XLR upload cable

## CONNECTIONS

AC power input.....	1.6# (15 AWG) mains cable prepared for direct tie-in or user-supplied cord cap
DMX data input .....	Neutrik locking 5-pin XLR male
Driver data output .....	Neutrik locking 5-pin XLR female

## ELECTRICAL

AC power .....	208–250V, 50/60 Hz
Maximum power consumption (all LEDs on).....	410 W
Standby power consumption (all LEDs off) .....	8 W

## TYPICAL POWER AND CURRENT

208 V, 60 Hz .....	405 W, 1.9 A, 0.99 PF
230 V, 50 Hz .....	405 W, 1.7 A, 0.988 PF
240 V, 50 Hz .....	405 W, 1.6 A, 0.988 PF
240 V, 50 Hz .....	405 W, 1.55 A, 0.988 PF
Peak inrush current .....	14 A

PF power factor is measured at full load with all LEDs 100% driven.

## FUSES

Main fuse (not user-replaceable).....	T5A
---------------------------------------	-----

## ACCESSORIES

SGM USB 5-Pin-XLR upload cable .....	P/N 40500201
--------------------------------------	--------------

\* Specifications subject to change without notice



## User's notes







SGM A/S · Sommervej 23 · 8210 Aarhus V · Denmark  
Tel +45 70 20 74 00 · [info@sgmlight.com](mailto:info@sgmlight.com) · [www.sgmlight.com](http://www.sgmlight.com)